

# Introduction to Locks and Keys

## HOW LOCKS WORK

### The First Known Locks

A *lock* is simply a mechanical device for securing a door so that only a key or a combination can open it. This study unit will introduce you to a variety of common locking devices and the basics of how locks work. We'll also discuss some standard locksmithing tasks and the tools used to perform them. Let's begin our discussion of locks and keys with a brief look at the history of locks.

For thousands of years, people all over the world have been using locks to secure their homes and valuables. The oldest known lock in existence was found in the ruins of a 4,000-year-old palace near Egypt. Amazingly, this ancient wooden lock is of a very similar design to the pin tumbler locks we use today. Instead of a key, however, the Egyptian lock uses a wooden opener that looks something like a toothbrush with pegs. Figure 1 illustrates the operation of the Egyptian lock.

#### The Romans

In later years (about 2,000–3,000 years ago), the ancient Romans introduced the first metal locks (mostly iron locks with bronze keys). The locks had simple mechanisms and were easy to pick open. So, Roman designers attempted to improve security by concealing the keyholes beneath ornamentation. The Romans designed the first padlocks in their area of the world (the Chinese invented a padlock independently in the East at about the same time). The Romans were also the first to make small-sized keys—in fact, Romans sometimes wore keys on their hands as rings (Figure 2).

**FIGURE 1**—This 4,000-year-old Egyptian lock used a pin tumbler mechanism similar to a modern lock.

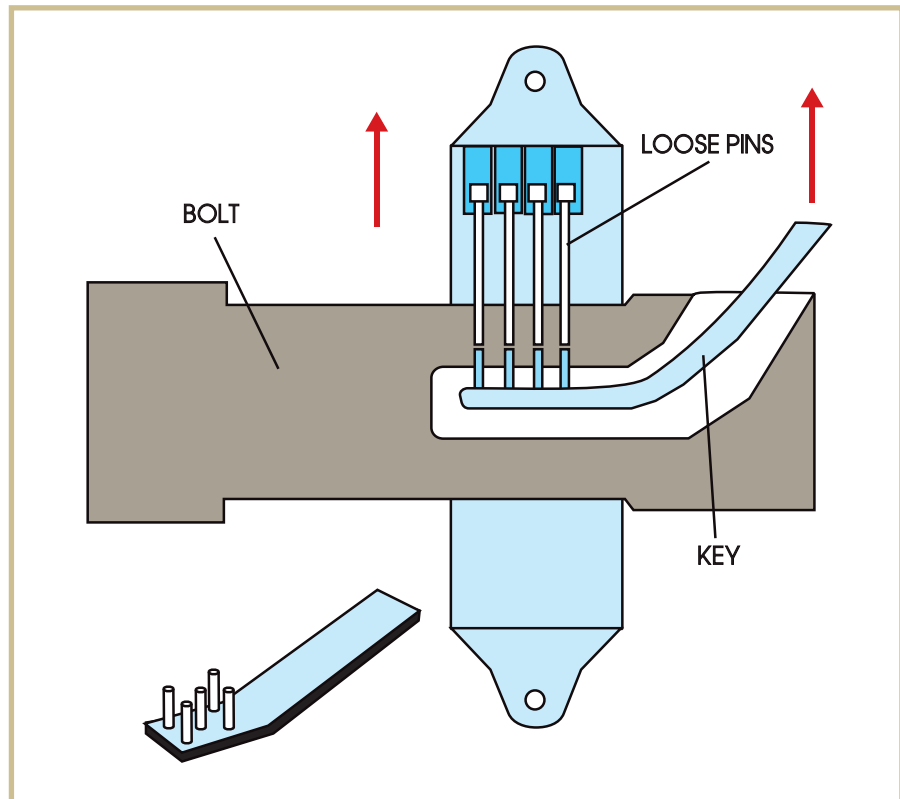

**FIGURE 2**—A Roman Ring Key

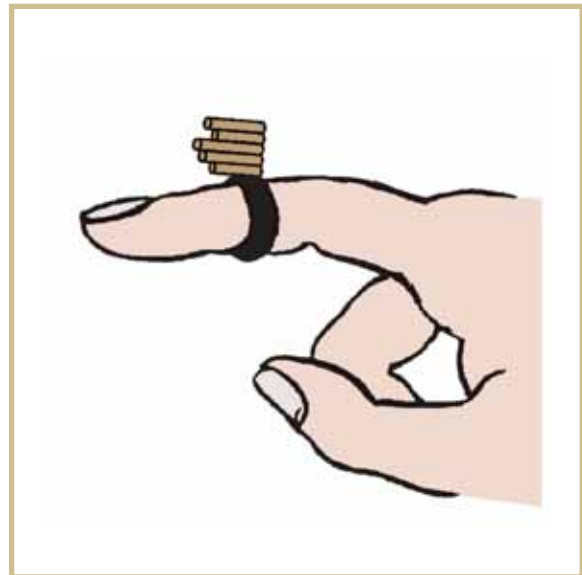

### The Middle Ages

During the Middle Ages, as metalworkers gained new skills, the outward appearance of the average lock changed. Most locks were elaborate, beautifully decorated, and cleverly designed works of art. However, few real advances were made in improving lock security.

The people of the Middle Ages paid more attention to chest or box locks than to door locks. Many wealthy people kept money, jewelry, and other valuables locked in chests. One technique for securing a money box involved placing several locks on the box — perhaps as many as 20! Another technique introduces hidden keyholes, false keyholes, and other devices in an attempt to make locks harder to open. One locking device even included a spring-loaded knife that would pop out and injure a thief if tampered with!

### The Nineteenth Century

Lock designers and metalworkers continued to develop their skills. By the time of the Industrial Revolution of the nineteenth century, the lock industry had expanded greatly. Many new lock designs were patented during this period, each offering improved security. The most important lock invention of the time was the patented device made in 1848 by the American inventor Linus Yale, the pin cylinder lock. The pin cylinder lock, also known as the Yale lock, was based on the same principle as the ancient Egyptian lock we discussed earlier. The special design of the lock allowed for an almost unlimited number of key variations, which made the lock very difficult to pick. While the original Yale-type lock has been improved upon over the years, its design is essentially the same as it was 150 years ago.

### Modern Times

As you've seen, locks have been used since ancient times to protect homes and property from intrusion and theft. Today, we use locks to secure almost everything—doors, gates, windows, cars, drawers, cash boxes, vending machines, safes, and even bicycles! In addition, many new electric and electronic security devices have been developed. A modern locksmith may service many different types of locks in just one week of work. Therefore, locksmiths generally try to familiarize themselves with all kinds of security products, even though most specialize in one or two skills.

## The Importance of Using Correct Terms

One of the best ways to gain locksmithing knowledge is to become familiar with locksmithing terms. As you learn the terms and phrases of the locksmithing industry, make them part of your everyday vocabulary. The better you understand the language of locksmiths, the better you'll understand what you read and hear about locks. In addition, by learning the locksmithing language, you'll be able to talk to other professionals, which is one of the most important ways to learn more about any field.

We included a glossary or dictionary of locksmithing terms in your first shipment of study materials. At any time during your reading, be sure to look up any unfamiliar words. This is the fastest way to learn new words and the best way to refresh your memory. We strongly encourage you to get into the "glossary habit."

Now, let's take a closer look at some locks you'll see every day as a professional locksmith. Have your glossary ready for reference! The first type of lock we'll discuss is the ordinary key-operated lock.

## Key-Operated Locks

### Basic Construction

The term *key-operated lock* simply means any type of lock that a key opens. (Note: Not all locks are opened by keys—some are opened by a combination of numbers, and some by electrical switches. We'll discuss these types of locks shortly.) The most common use of key-operated locks is in residential doors.

A key-operated door lock has these three main parts: (1) a *plug* and the *cylinder* that surrounds it, (2) a *latch* or *bolt*, and (3) a *key*. Let's look at each of these parts separately.

### Plugs

The *plug*, and the *cylinder* that surrounds it, is the central assembly of a key-operated lock (Figure 3). The plug is the tube, which contains the small parts that operate the bolt or latch. The cylinder is the tube assembly that surrounds and holds the plug. The cylinder holds the small parts firmly in the plug and prevents them from spilling out.

**FIGURE 3**—This illustration shows a lock cylinder that contains a plug, and a view of the plug when it's removed from the cylinder.

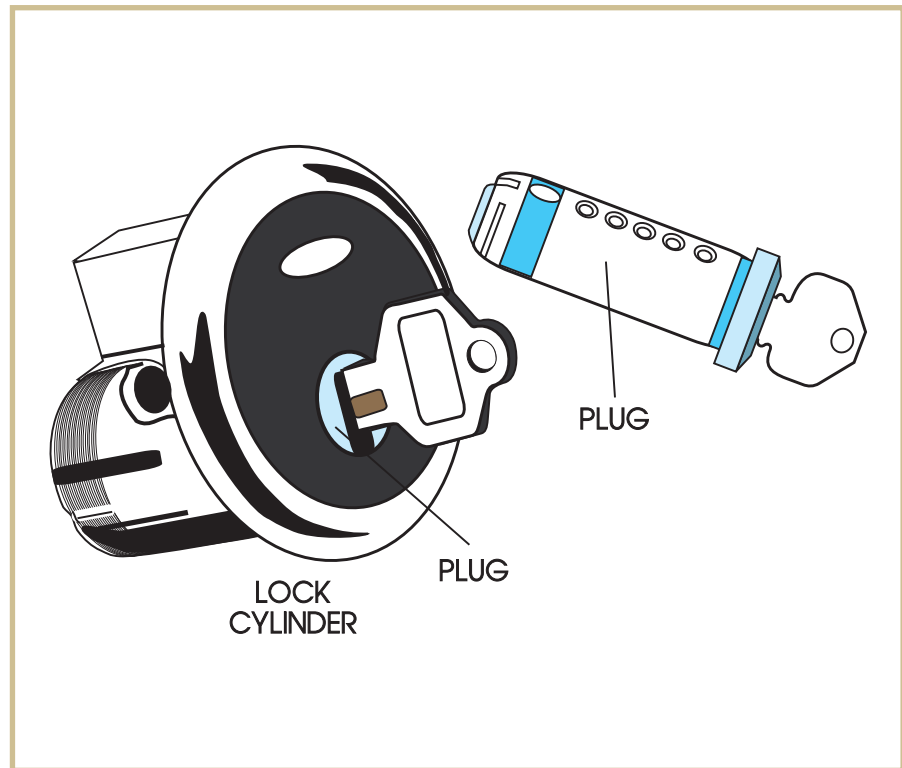

The *keyway* is the “tunnel” in the plug that a key slides into. The inside of a keyway isn’t completely smooth. Instead, the keyway is grooved and notched to allow only the correct blank to enter. When you insert the correct key into the keyway, the small parts inside the plug move in such a way that the plug is freed to turn. As you turn the key, you’ll turn the plug with it, locking (or unlocking) the door.

Some key-operated locks have more than one cylinder. For example, if you want to be able to lock a door on either side with a key, you can install a *double-cylinder lock*. You’ll often find double-cylinder locks on the doors of a business.

### Latches and Bolts

A key-operated door lock may have a latch, a bolt, or both. A *latch* is a piece of metal that protrudes out of the lock and fits into a recessed space in the door frame (Figure 4). This recessed space is a *strike*. The end of the latch is cut at an angle and is mounted in front of a spring. As the door closes, the latch contacts the strike, presses against its spring, and snaps into place in the strike. This leaves the door securely closed, but not locked. To open the door, you simply turn the doorknob.

**FIGURE 4—A Typical Door Latch**

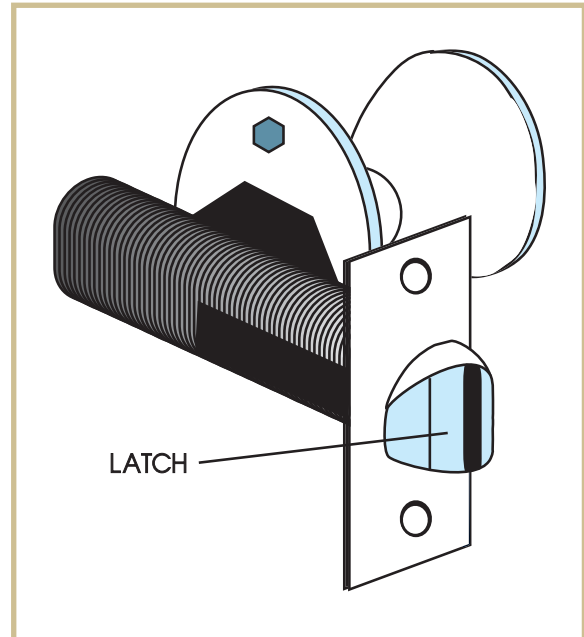

A *bolt* is also a strong piece of metal that protrudes from a lock to fit into a strike (Figure 5). However, a bolt has a squared-off end and is usually longer than a latch, so it fits more deeply and securely into a strike. Also, a bolt isn't mounted with a spring. Instead, a bolt is thrown into the strike either by turning a *thumbpiece* by hand, or by using the key. When a bolt is in place, a door is both securely closed *and* locked. The door can't be opened by just turning the doorknob; the bolt must be withdrawn from the strike first by using a key or turning the thumbpiece.

**FIGURE 5—A bolt has a squared-off end to fit deeply and securely into a strike.**

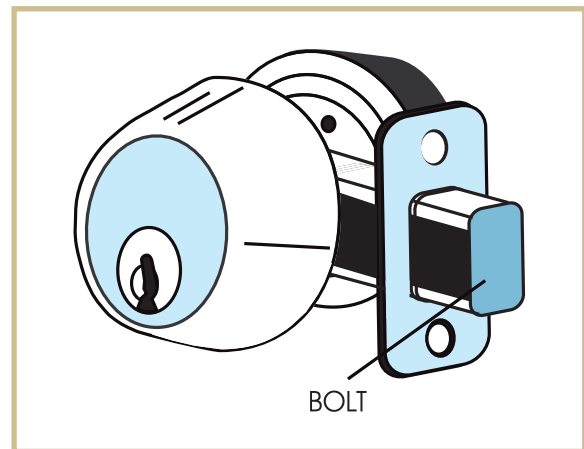

The strike is a vital part of the security of any door lock. A strike is a molded metal piece that's fitted into the door frame and secured by screws. However, a strike is only as strong as those screws; if the screws are weak, the lock can be defeated by simply kicking the door in. The most secure strikes are embedded deeply into the door frame, adding strength to the entire locking system (Figure 6).

**FIGURE 6**—This figure shows a typical strike mounted in a door frame.

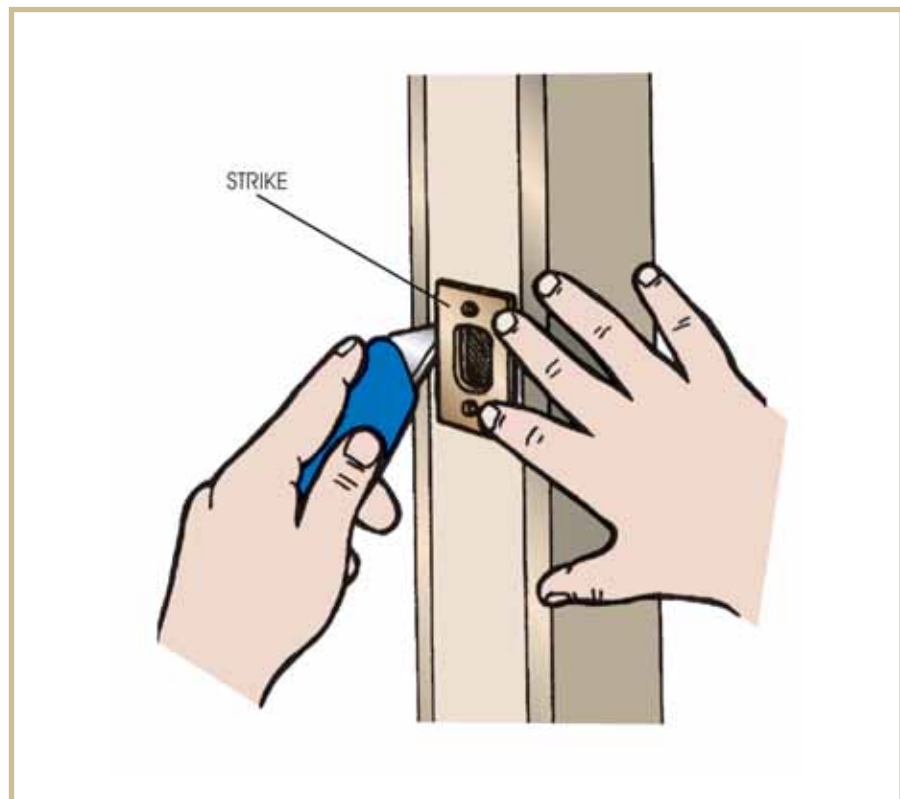

## Keys

A *key* is simply the small, shaped piece of metal used to open a lock. There are five basic key types, and you're probably familiar with most of them. The four basic key types are

1. Bit keys
2. Barrel keys
3. Lever keys
4. Cylinder keys

Each of these key types goes with a certain type of lock. As you gain locksmithing knowledge, you'll quickly learn to identify locks by the types of keys used with them.

The *bit key* (Figure 7) is the oldest type of key and was once common for front doors. If you live in a very old home, you may still use a bit key for certain interior doors (closets, attic and basement doors, cabinets, etc.).

**FIGURE 7—The oldest type of key still in use today. The bit key was also known as a skeleton key.**

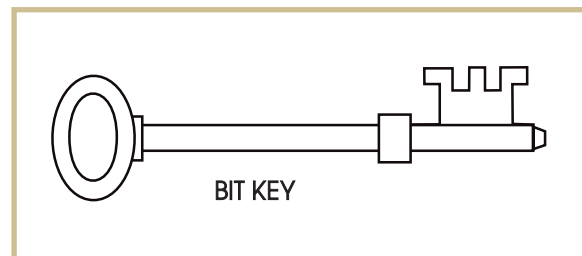

The *barrel key* is a variation of the bit key, and like the bit key, is old-fashioned and seldom used anymore. Barrel keys are round and hollowed out at the end (Figure 8). We use them to open china closets, interior doors, and some older padlocks.

**FIGURE 8—Barrel keys are a hollow variation of the bit key.**

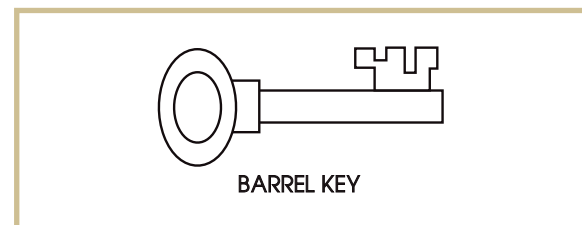

One modern version of the barrel key is the *tubular key* (Figure 9). Tubular keys are short, round, and hollowed out like the barrel key, but they function a bit differently. We use tubular keys in the locks on vending machines, coin-operated laundry machines, and computers.

**FIGURE 9—We use tubular keys with vending machine locks and computer locks.**

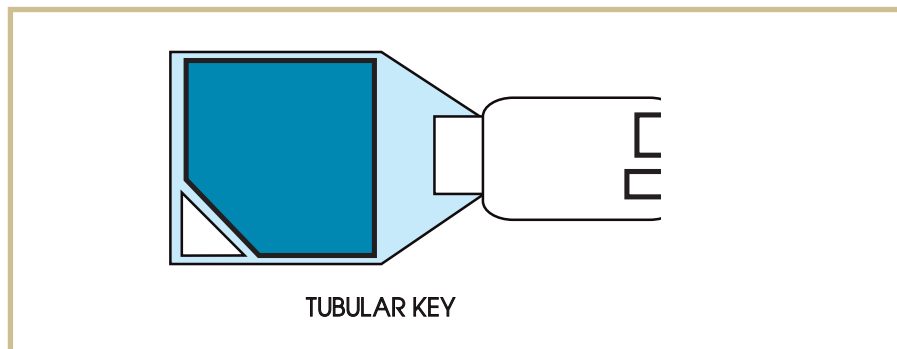



*Lever keys* are made from thin, flat pieces of steel (Figure 10). These flat keys have no grooves; they're completely smooth on both sides. We use lever keys for some small padlocks and also for safe-deposit box keys.

**FIGURE 10—Lever keys have no grooves—they're completely smooth and flat.**

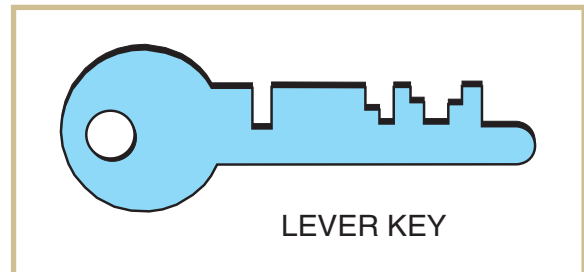

The most common type of key used today is the *cylinder key* (Figure 11). If you look on your own key ring now, you'll probably find several cylinder keys. We use cylinder keys for most front door and car locks, as well as padlocks.

**FIGURE 11—Cylinder keys are the most common type of key used today.**

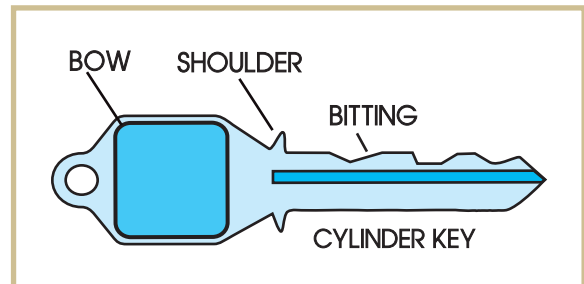

Three parts are common to most types of keys. These three parts are the bow, the shoulder, and the bitting (refer back to Figure 11). The *bow* is simply the handle of a key. Most lock manufacturers have their own distinct and recognizable bow shapes. All keys have a bow.

Just below the bow is the *shoulder* of the key. The shoulder of a key is slightly wider than the rest of the key's length. The shoulder prevents the key from being pushed too far into a lock.

The *bitting* is the pattern of notches cut into the edge of the key. The first notch is always cut just below the key's shoulder. The locksmith can make these notches with a key cutting machine, or by hand with metal files. Most keys have this type of bitting. One exception is the tubular key in which the bitting runs around the circular end of the key.

To make a new or duplicate key for a customer, a locksmith begins with a *key blank* (Figure 12). A key blank is simply an uncut key. All key blanks aren't alike. Each lock will accept only one type of key. A key blank must exactly match the length, width, thickness, shape, and groove pattern of the original key to fit the lock.

**FIGURE 12**—This figure shows a cylinder key blank.

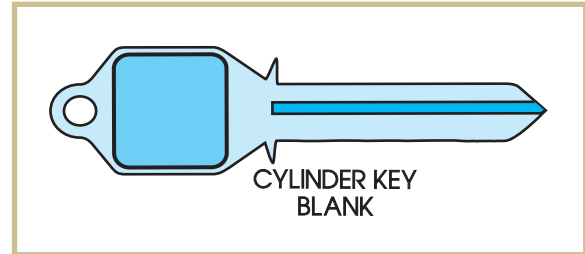

## Lock Mechanisms

Now that you understand the basics about keys, let's take a look at the locks that we use them with. A lock *mechanism* is simply the assembly of parts inside the lock that makes it work. There are only four common mechanisms used inside modern key-operated locks. They are

1. The *warded* mechanism
2. The *lever tumbler* mechanism
3. The *disk (or wafer) tumbler* mechanism
4. The *pin tumbler* mechanism

Let's take a closer look at these lock mechanisms now.

### The Warded Mechanism

The *warded* lock mechanism is the oldest type of lock still in use today. The ancient Roman locks we talked about earlier contained *warded* mechanisms. A *warded* lock works on a very simple principle. The interior of the lock has protruding ridges called *wards* that prevent the wrong key from being inserted to throw the bolt. Figure 13 shows a lock mechanism with an edge ward. Note that we use bit keys with most *warded* locks. Figure 14 shows a slot milled on the edge of the key, which allows the key to pass a case ward.

**FIGURE 13—A Warded Lock Mechanism Showing an Edge Ward**

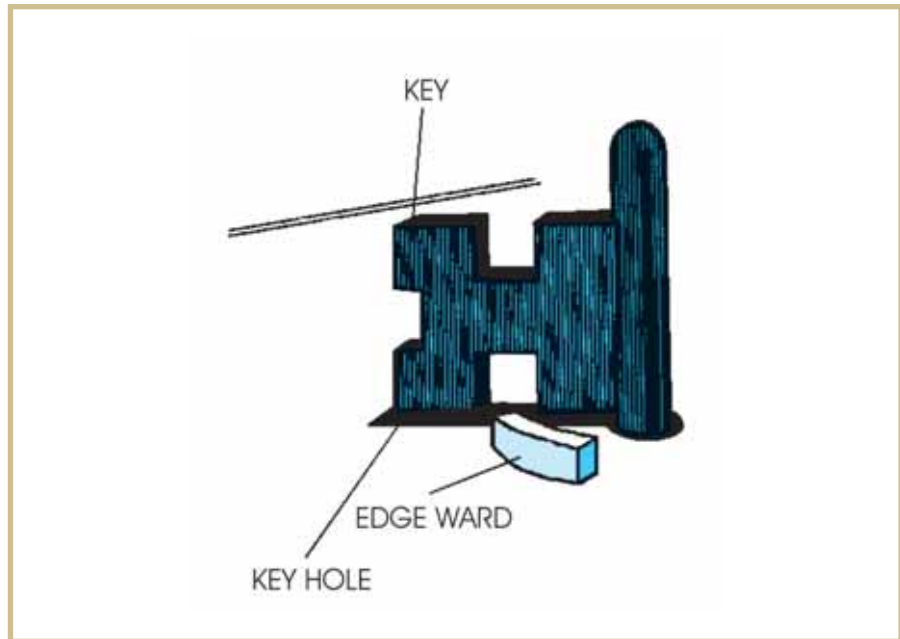

**FIGURE 14—A Warded Lock Mechanism Showing a Case Ward**

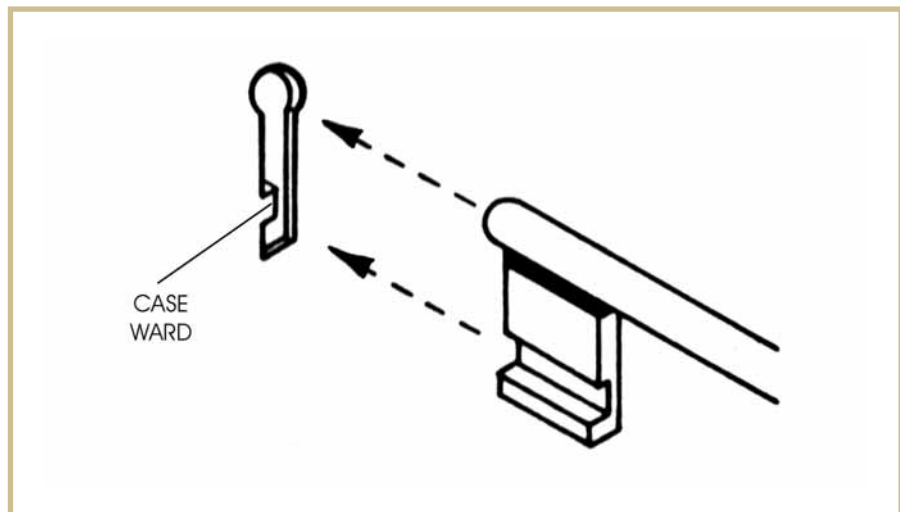

Warded locks were once commonly used as door locks. However, because they're very easy to pick, we seldom use them anymore. However, small warded padlocks are still common. The advantage of simple warded padlocks is that we can use them where sand, dirt, or ice may jam a more complex mechanism (on toolshed doors, toolboxes, in boats, etc.). Modern warded padlocks (Figure 15) don't use bit keys; they use lever keys.

Locksmiths still occasionally see some warded locks in very old homes. However, whenever you see these locks, you

should recommend replacement (or at least reinforcement) with a newer, more secure lock.

**FIGURE 15**—This warded padlock uses a lever key.

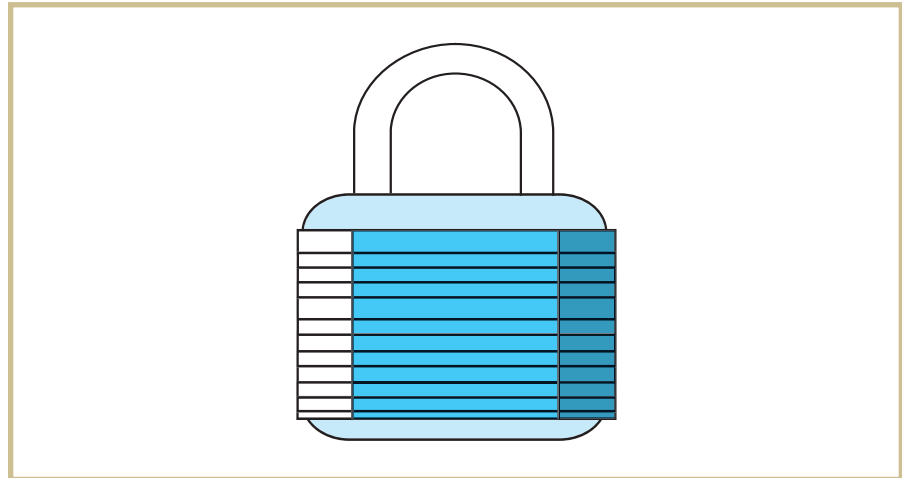

### The Lever Tumbler Mechanism

*Lever tumbler* locks (Figure 16) have flat metal plates that must slide into place for the lock to operate. As the correct key is turned, it will move the plates just enough to allow the lock to work. The flat design of the lever lock makes it suitable for use on school lockers, mailboxes, luggage, cash boxes, and safe-deposit boxes. Lever locks are much more difficult to pick than warded locks.

**FIGURE 16**—We use this type of lever lock on gymnasium lockers and mailboxes.

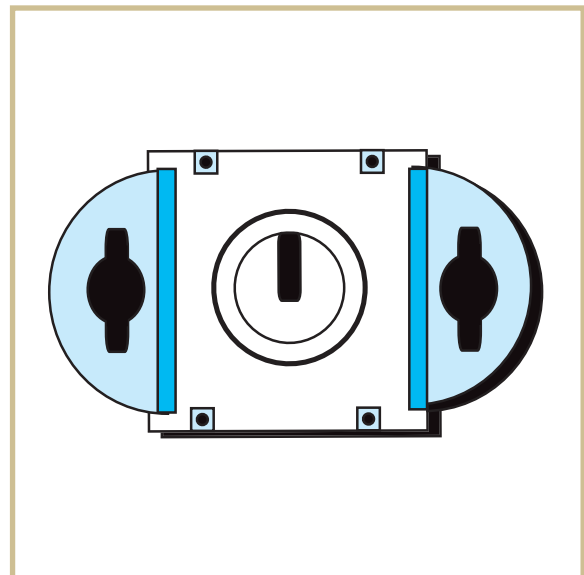

### The Disk Tumbler Mechanism

The *disk tumbler* lock mechanism (Figure 17) is designed with a keyway surrounded by a cylinder. The cylinder contains rectangular metal disks that can move up and down. When you insert the correct key into the keyway, the disks are raised to the proper level, and the cylinder is freed to turn, opening the lock. Disk tumbler locks are most commonly used in automobile doors and as desk locks in offices.

**FIGURE 17**—We use this type of disk tumbler lock on desk drawers.

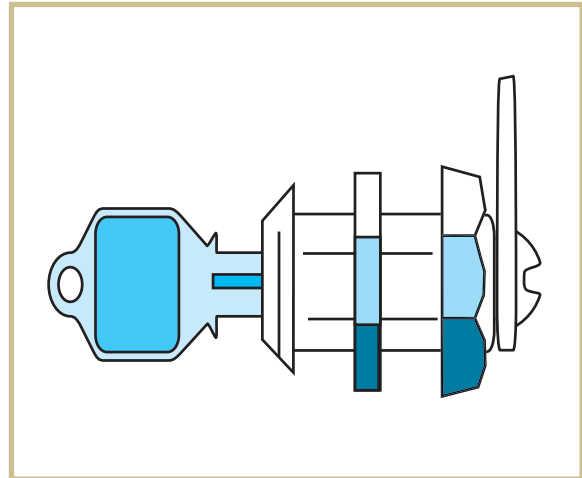

### The Pin Tumbler Mechanism

The *pin tumbler* lock mechanism is the most secure in use today. You'll commonly find it in cars and residential doors. The pin tumbler lock, like the disk lock, has a keyway surrounded by a cylinder. Small metal pins align in a row along the length of the cylinder. The pins are of different heights, and can move up and down freely. When you insert the correct key into the keyway, the pins move to the correct height, the cylinder turns, and the lock opens (Figure 18).

Pin tumbler locks are very secure and are difficult to pick, though not impossible. For this reason, a special type of high-security pin tumbler lock is also available today. Such locks contain four rows of pins and require a special type of key (usually a dimple key) to open. High-security pin tumbler locks are virtually impossible to pick open.

As we mentioned before, keys aren't the only way to open locks. Let's now discuss combination locks.

**FIGURE 18**—This figure shows an interior view of a pin tumbler cylinder with the key inserted.

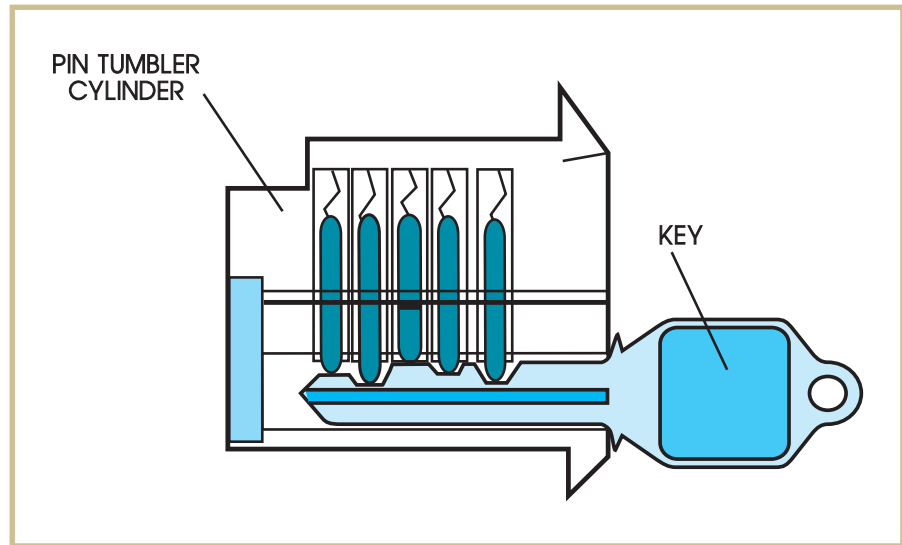

## Combination Locks

### Combination Lock Construction

A *combination lock* is a type of lock that you open by dialing a series of numbers instead of inserting a key. Combination locks have a numbered dial face with a knob. You turn the knob both clockwise and counterclockwise to certain numbers on the dial. Dialing the proper series of numbers releases the lock's internal mechanism, opening the lock's shackle. Figure 19 shows a typical combination padlock.

**FIGURE 19**—A Combination Padlock



The main parts of a combination padlock's inner mechanism are the *wheels* or *tumblers*. Most lock combinations contain three tumblers and a dial with its knob.

When you turn the knob on the dial face, you're actually turning only the first tumbler until it properly aligns with the second tumbler. Now, these two tumblers turn until they align with the third tumbler. Now, all three tumblers will turn as you rotate the dial knob. Once all three tumblers line up correctly, the lock will open. While some combination locks have more than three tumblers, they all operate on this same basic principle.

Combination locks provide greater security than keyed locks. A three-tumbler combination lock is practically impossible to defeat by trying random combinations. There are up to a million possibilities, and only one correct one. A combination lock with more than three tumblers will have even more possible combinations. That's why you find combination locks on safes and bank vaults.

Another advantage of combination locks is that you can change the combination easily (except in the most inexpensive padlocks). To maintain security, companies and stores frequently change the combinations on their safes when employees leave.

### Types of Combination Locks

There are many types of padlocks, door entry systems, and safes that use a combination lock. Some combination locks, such as those on safes or rooms that contain classified information, are connected to automatic lock timers. The time clock is set for a particular time at which the lock opens or allows you to use a combination to open the safe. Such locks are *time locks*.

Time locks provide a double-lock security system. In banks, for example, the timers may be set to go on at 5:00 P.M. each day and off at 8:00 A.M. In businesses, time locks unlock all doors automatically at a certain time, eliminating the need to have a security officer open each door for employees.

*Push-button combination locks* (Figure 20) require the user to press one or more buttons together or in a sequence. The correct pressing of the buttons opens the lock. These locks are mechanical—they don't use electricity to operate.

**FIGURE 20**—This illustration shows the operation of a push-button combination lock.

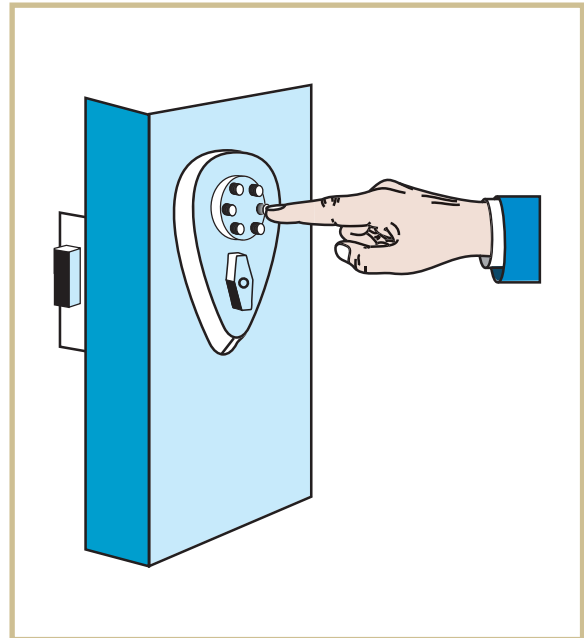

Most homes, businesses, and banks use a variety of safes of all sizes. Models are available that install in floors, walls, or under counters. In addition, specialty safes can store and protect rifles, pistols, and paper documents. Most safes are made of thick steel and are insulated with a fire wall (Figure 21). A business safe or vault that's fire-resistant as well as secure protects the contents from all kinds of destruction.

**FIGURE 21**—Homes and businesses commonly use this type of standing safe.

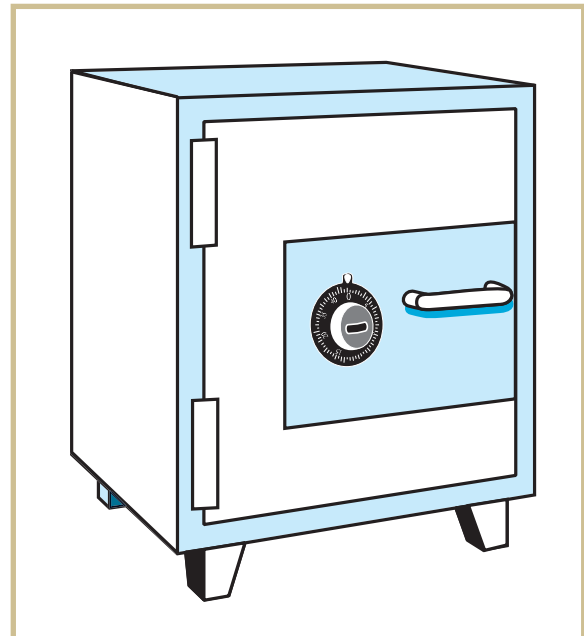



While safes will require occasional repairs, cleaning, and lubricating, the most common service calls for a locksmith are to change safe combinations.

## Electric Locks and Electronic Security

### Electric Locks

Electrically operated locks and release latches are commonly used on the doors of large office and industrial buildings. The locks typically open with a code number punched into a key pad or with a card key. *The card key lock* operates by inserting a coded plastic card into the door lock. The card has a magnetized strip that actuates the lock. You'll find the card key lock used in many hotels and motels.

Electric locks can provide extra security since they remain locked most of the day. Only authorized employees and security personnel are able to open the locks.

### Electronic Security Devices

The rising crime rate and the fear of home burglary has made the installation of electronic security devices a lucrative locksmithing specialty. There are two basic types of alarm systems: local and central.

A *local alarm* sounds only at the building where it's installed. This type of alarm can alert neighbors and scare away would-be intruders. *Central alarms* connect to a monitor station owned and monitored by a private alarm company.

Some typical electronic security devices include the following.

**Foil.** Foil is a metallic ribbon that attaches to glass (Figure 22). When anyone breaks the window, the foil breaks and triggers an alarm.

**Pressure mats.** Pressure mats are alarm pads placed in doorways, hallways, stairways, and under carpets. The alarm mat contains a flat switch that sets off an alarm when it senses the pressure of footsteps.

**FIGURE 22**—This illustration shows the installation of foil in a store window.

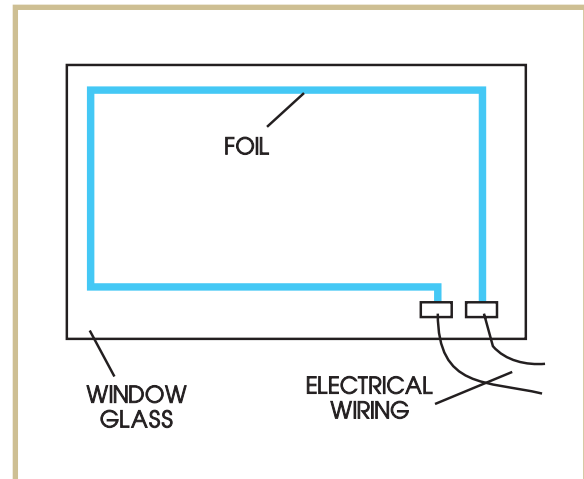

**Vibration detectors.** A vibration detector is a sensor device that feels the vibrations of an attacker on walls, floors, and ceilings. When the detector senses such vibration, the system triggers an alarm.

**Photoelectric beams.** A photoelectric beam device (also called a motion detector) looks like a standard wall outlet and sends beams of infrared light across hallways, rooms, and stairwells (Figure 23). The beams are invisible to the naked eye, but when an intruder walks through the beams, an alarm sounds.

**FIGURE 23**—If an intruder walks through a photoelectric beam, an alarm will sound.

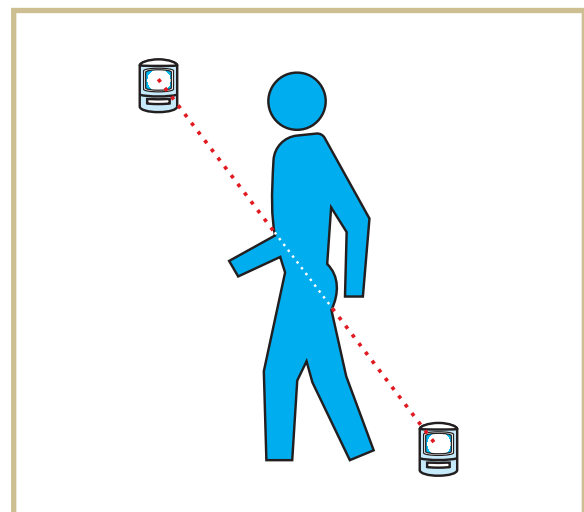

**Panic buttons.**

A panic button is a device that you would most often find below counters in retail stores. If a robber enters, the clerk or cashier can press the button to sound an alarm.

Now, before proceeding to the next section of the text, take a few moments to test your knowledge of what you've read by completing *Locking It Up! 1*.

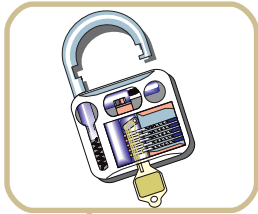

## Locking It Up! 1

At the end of each section in *Introduction to Locks and Keys*, you'll pause and check your understanding of what you've just read by completing a "Locking It Up!" quiz. Writing the answers to these questions will help you review what you've studied so far. Please complete *Locking It Up! 1* now.

Fill in the blanks in the following statements.

1. A \_\_\_\_\_ lock is any type of lock that a key opens.
2. The \_\_\_\_\_ is the tube assembly that surrounds and holds the plug.
3. If you want to be able to lock a door on either side with a key, install a \_\_\_\_\_ lock.
4. The five basic key types are \_\_\_\_\_, \_\_\_\_\_, \_\_\_\_\_, \_\_\_\_\_, and \_\_\_\_\_.
5. The \_\_\_\_\_ is the handle of a key.
6. The \_\_\_\_\_ is the pattern of notches cut into the edge of the key.
7. A \_\_\_\_\_ has a squared-off end, while a latch has an angled end.
8. The four mechanisms used in modern locks are \_\_\_\_\_, \_\_\_\_\_, \_\_\_\_\_, and \_\_\_\_\_.
9. The \_\_\_\_\_ lock mechanism is the oldest type of lock still in use today.

Check your answers with those on page 57.